



Seawind, an Offshore Wind Revolution

Sustainable, abundant, low cost energy generation



Seawind – Preparing for the Demonstrator 2.0



Gamma 60, the world's first full variable speed wind turbine, 1991, proof of the Seawind concept of yaw control with teetering hinge

- 1975** [Glidden Doman](#), helicopter expert, leads NASA & United Technology project for the development of multi megawatt wind turbines: WTS-4 (4 MW) Wyoming, USA (in full production until 2002) and WTS-3 (3 MW) in Sweden
- 1991** Glidden Doman introduces the **yaw control principle** in the **Generation 1.0** two-bladed **1.5 MW Demonstrator** Gamma 60 with teetering hinge, Aeritalia (now Alenia), Finmeccanica, Sardinia, Italy
- 2003** Glidden Doman and Silvestro Caruso (Co-founder Seawind) buy Gamma 60 technology
- 2004** Martin Jakubowski (Co-founder Seawind) sets up Blue H
- 2007** Silvestro Caruso starts upsizing and upgrading the Gamma 60 technology in Blue H
- 2008** World's [first floating wind turbine installed](#) in the Southern Adriatic Sea by Blue H
- 2014** Seawind Ocean Technology develops the complete Seawind 6MW offshore wind energy system (turbine, support structure and how to install it at sea)
- 2017** **Seawind Systems AS builds the 6.2 MW Generation 2.0 Demonstrator in Norway**

Seawind Technology – Based on fundamental NASA research



Tremendous public support after the first oil crisis for wind turbine development in the United States by NASA and U.S., allowed for construction and operation of **4 MW WTS 4, 1982**, in Wyoming, United States. Until today the wind turbine with the highest wind energy production.

- In the 70s/80s the United States developed Wind turbines to generate electricity on a large, utility scale (multi megawatt installations). After the first oil shock (1974) President Jimmy Carter dedicated \$330 m to a research programme for the development of multi megawatt wind power plants. The program was cancelled as oil prices fell back to the low levels.
- NASA wind and the US aviation industry developed specific simulation software based on their helicopter industry experience. Their models showed 2-bladed wind turbines have superior economics.
- Europeans did not have such simulation software in the 70s and chose for ongoing development of the three bladed turbine (trial & error method).
- Once oil prices went down again the United States were no longer interested in wind turbines, they abandoned the wind industry.
- The EEG created a market for wind turbines, which followed the Danish three-bladed wind turbine design, first in Germany, then Spain then in many other countries. This design was later adapted for offshore and although sub-optimal, is the standard today.



Private power generation by farmers in Denmark was the basis of the 3-bladed rotor turbine development, here the **30 kW Vestas V10 (1982)**

Seawind - Upgrading NASA Wind Turbine Technology

A number of the world's largest wind turbines were developed and tested under the [NASA](#) program led by Glidden Doman. Silvestro Caruso (Seawind CTO) and Glidden bought the Gamma 60 technology based on the NASA results in 2003.

2-bladers built 1970 – 1990

The WTS-4 (4 megawatt) wind turbine in Wyoming designed by United Technologies (Hamilton Standard Division).

- “soft” steel tube tower
- Fiberglass blades
- Torsional springs and dashpots in the drivetrain
- Flexible teetered hub.

To this day, the WTS-4 is the most powerful wind turbine to have operated in the US and it held the world record for power output for over 20 years.

A second commercial prototype with a smaller generator (3 megawatts) designated the WTS-3 was constructed and operated in Sweden.



Gamma 60 built by Seawind CTO on Sardinia

In 1991 Glidden Doman (NASA research) introduced the yaw control principle in the Generation 1.0 two-bladed 1.5 MW Demonstrator Gamma 60 with teetering hinge, built by Aeritalia and Finmeccanica.

The Gamma 60 was the world’s first full variable speed wind turbine and proof of the Seawind concept of yaw control and teetering hinge. Seawind’s CTO Silvestro Caruso was responsible for the design review.

In 2003 Glidden Doman and Silvestro Caruso (Co-Founder Seawind) bought all Intellectual Property of the Gamma 60 technology.

The Gamma 60 data are now used to develop the Seawind 6 Demonstrator.



Seawind Economics – Superior and Robust

	NOW		2022	
	Seawind 6.2	Bloomberg Benchmark*	Seawind 10 ^{plus}	Industry Target ^{***}
CAPEX (€ million/MW)	2.4	4.0	1.8	2.5-2.8
LCOE (€ /kWh)	0.07	0.126	0.039	0.08



40% more economical



30-40% more economical

* Bloomberg New Energy Finance: <https://about.bnef.com/blog/h2-2016-lcoe-giant-fall-generating-costs-offshore-wind/>

** www.gwec.net/wp-content/uploads/2016/06/160603-FINAL-Offshore-wind-cost-reduction-statement-with-annex.pdf

Seawind - Turbine Portfolio Yields

Seawind 6.2MW	Rotor size	Cost/MW
	126 m	€2.4 million

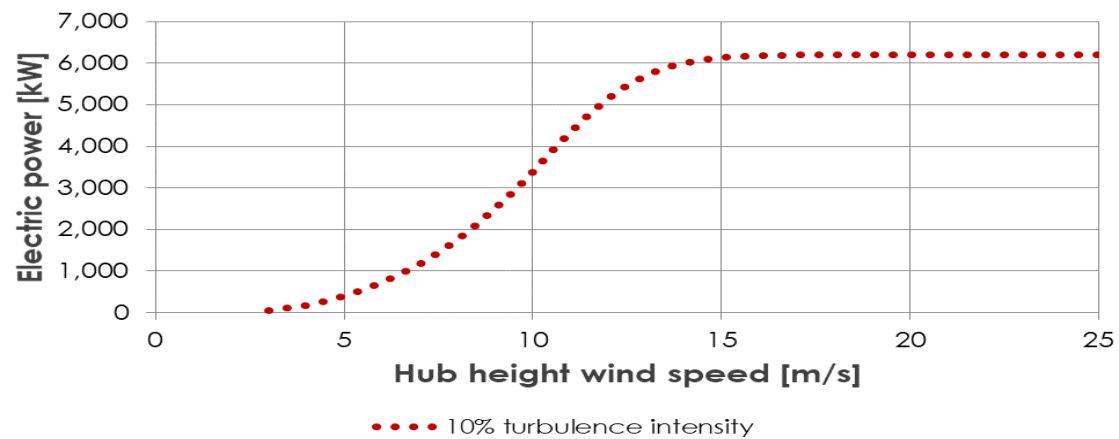
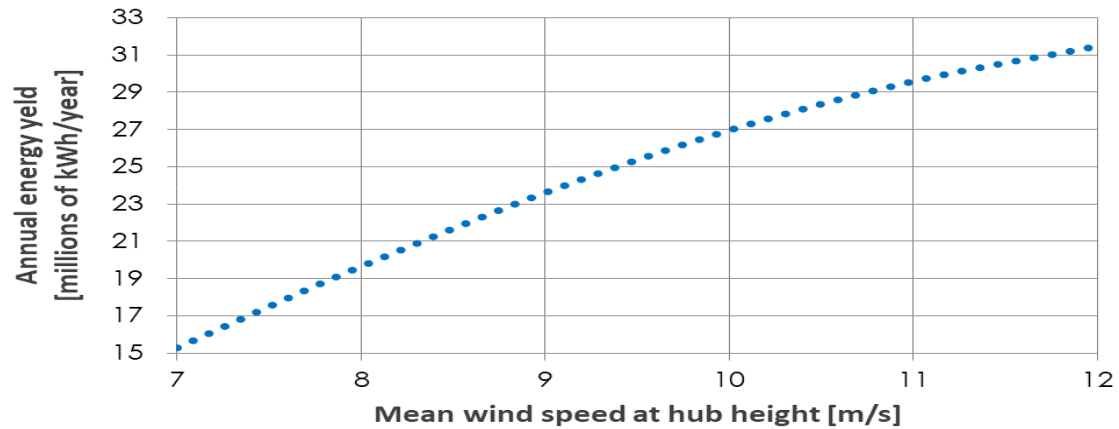

Seawind 10MW	Rotor size	Cost/MW
	210 m	€1.8 million

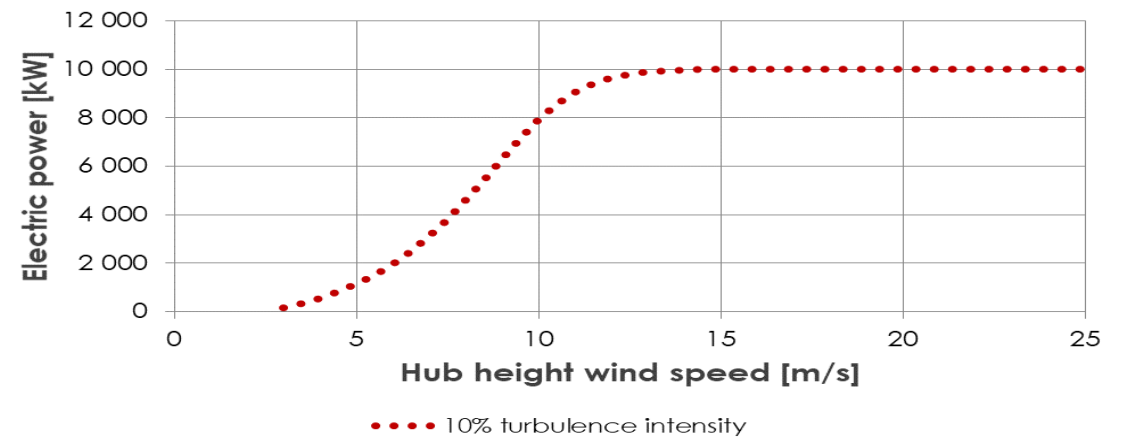
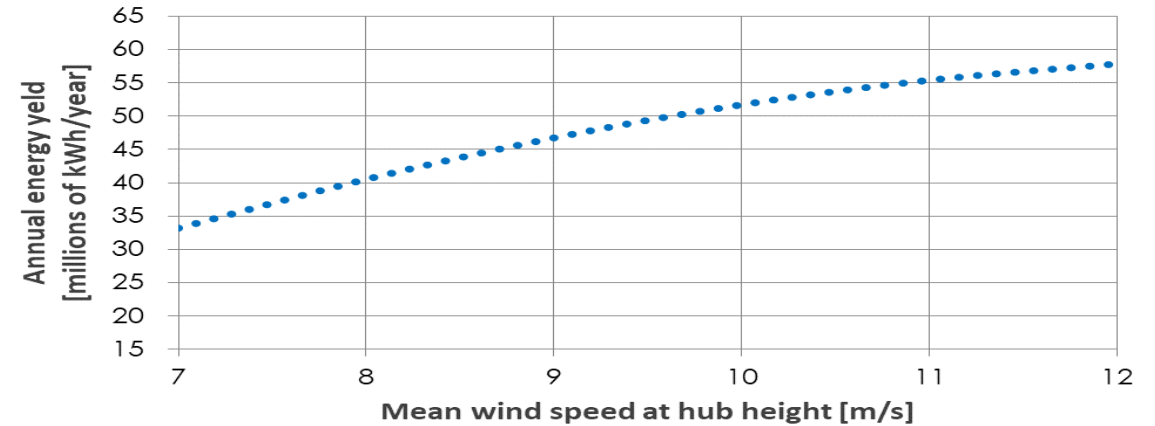

Seawind – Lower LCOE, fit for Cyclones and for Floating

Key benefits for the 2-bladed Seawind turbine technology

- **Lower Capex and Opex** than any other offshore wind solution
- **Lowest life cycle cost** for offshore wind farm systems, below € 0,07 per kWh installed offshore, aiming for below € 0,04 per kWh for 10+ MW.
- **Easy installation** everywhere, avoiding costly heavy lifting or installation vessels and harbor infrastructure
- **Robust design** with reduced fatigue values and low-cost onboard maintenance and repair
- **Wind Turbine Lifetime of 30+ years** compared to 20 years for traditional three-bladed offshore wind turbines

Global Offshore Wind Energy Potential in GW (%)

(Report Gerard Hassan 2010)

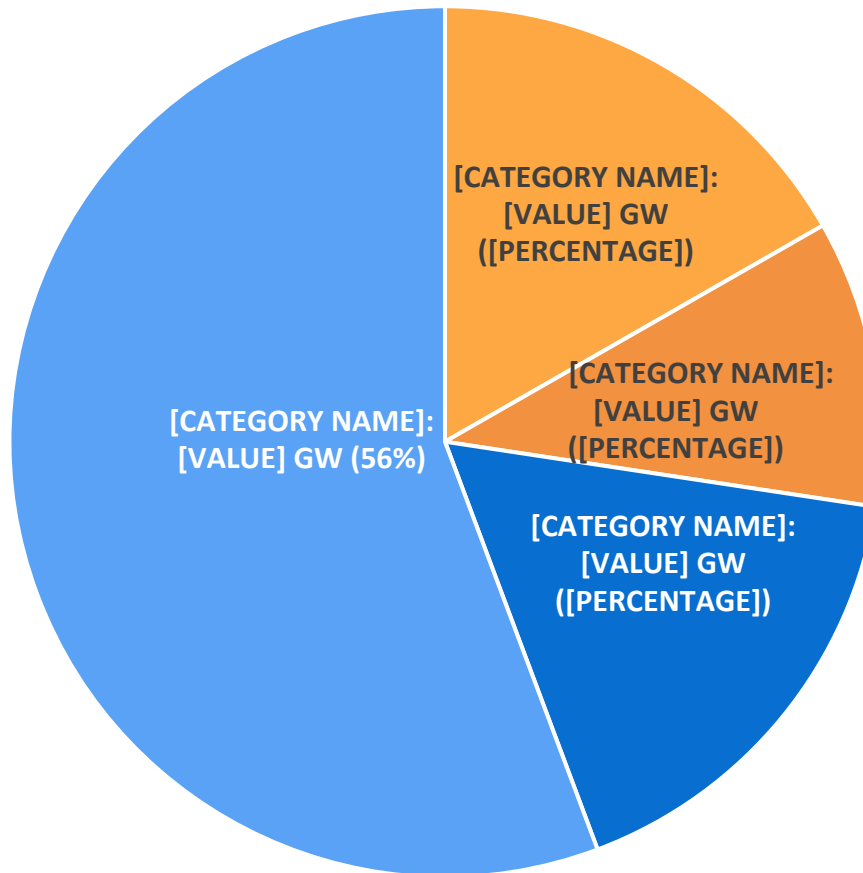

Benefits in Cyclone areas

Seawind can withstand:

- Strong winds up to 90 m/s in cyclones, hurricanes and typhoons

Key benefit for floating systems

Lower cost as the Seawind technology has:

- About 50% less weight of turbine head and steel tower combined, therefore lower overturning moment

Seawind – Bringing the technology forward



A COSCO semi-submersible heavy transport vessel delivering four complete Seawind 6 units to the offshore wind farm site

Two-Bladed - with Elastic Teetering Hinge

- The Seawind 6 rotor is linked to the shaft via an **elastic hinge**, allowing the rotor to move like a see-saw while rotating (**helicopter rotor principle**)
- **Wind turbine is no longer a gyroscopic system**
- Due to action of the teetering hinge, the **fatigue values of the Seawind 6 are dramatically lower** than any other wind turbine
- Less fatigue values = less O&M costs, **longer lifetime**

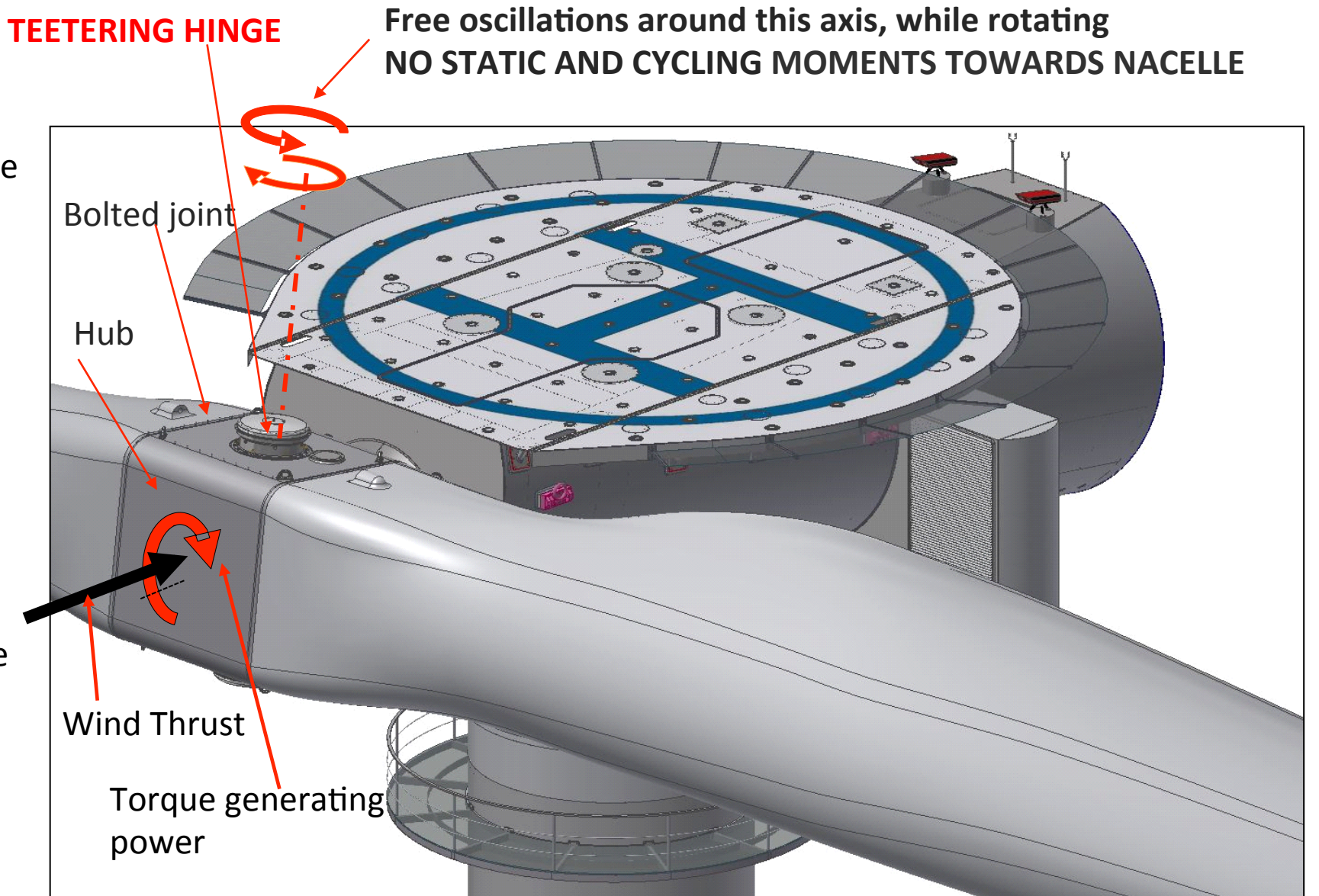

Seawind's - Offshore Wind Turbine with Teetering Hinge

- 6.2 MW two-bladed **upwind** teetering hinge turbine **with yaw control**
- Concrete support structures for shallow, medium and deep water (floating)
- Light weight and long-lived (25 years design life plus life extension program to 30+ years)
- Easy to handle: no large star-shaped rotor
- Hurricane resistant
- Designed for maintenance and repair on board
- Double access: via sea and via air
- **Lowest Capex, lowest Opex, lowest LCOE**



Power Control – Eliminating complexity

SEAWIND TURBINE



Yawing

DIFFERENCES

- Low wind speeds: rotor is kept into the wind, as in three-bladers
- High wind speeds: Seawind controls power **turning the turbine head out of or into the wind (yawing)**
- Three-bladers control power by **turning the blades around their axis (pitching)**
- The blade pitch mechanism is the largest failure source in three-bladed wind turbines; Seawind eliminates this complex mechanism

THREE-BLADED TURBINE



Pitching

Ability to withstand - Hurricanes (Typhoons)

SEAWIND TURBINE

Laser (LIDAR) detects wind up to 2km ahead.

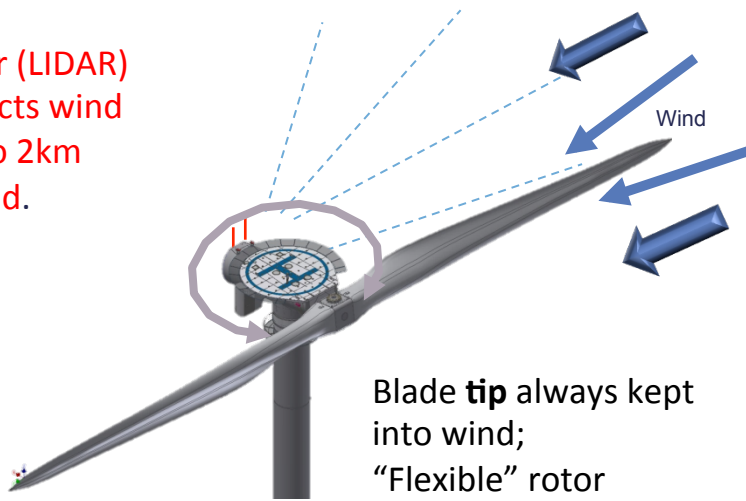

Seawind is yawed based on LIDAR information

Blade **tip** always kept into wind;
"Flexible" rotor behaves like palm tree in storm

DIFFERENCES

- In hurricanes **Seawind** points blade tips into the wind in a "flexible configuration"
- Seawind's LIDAR (laser detector) detects hurricane or strong gusts well ahead
- In Seawind 6, during hurricanes, the loads on blades and drivetrain are similar to normal operations
- Seawind's "flexible rotor" is compliant with the forces of nature and not facing them
- Results of simulation: Seawind can withstand Category 5 hurricanes (250 km/h) without damage
- **Three-bladers** are parked with blades pitched at 90°, the tip chord parallel to rotor shaft, and its leading edge into wind
- Three-blader's configuration cannot eliminate risk of major damage or total loss

THREE-BLADED TURBINE

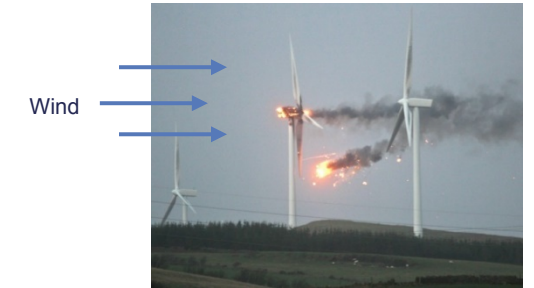

- Photo: 3-bladers at Ardrossan wind farm after major storm
- Typhoon Usagi (Hong Kong, in 2013): 70% of 24 Vestas turbines damaged, 8 turbines blown off: <http://goo.gl/X1jSF6>
- Study: up to 50% of US offshore wind turbines would be destroyed over a 20 year period by hurricanes: <http://goo.gl/gcEgDA>

Concrete Gravity Foundation – Installed by Sinking

- Seawind uses **floating concrete foundations**: cheaper, when industrialized (serial production), longer life time (up to 100 years, two turbine generations per turbine), no corrosion protection devices; less CO2 emission for concrete compared to steel
- Seawind cooperates with the renowned Norwegian company [Olav Olsen](#) on concrete foundations, famous for the **Troll A** concrete platform of 472 meters high
- Concrete support structure made on pier, completed with nacelle and rotor on pier and **launched as complete unit by sinking, no lifting!**
- **The complete system** is installed in a rapid one-shot operation

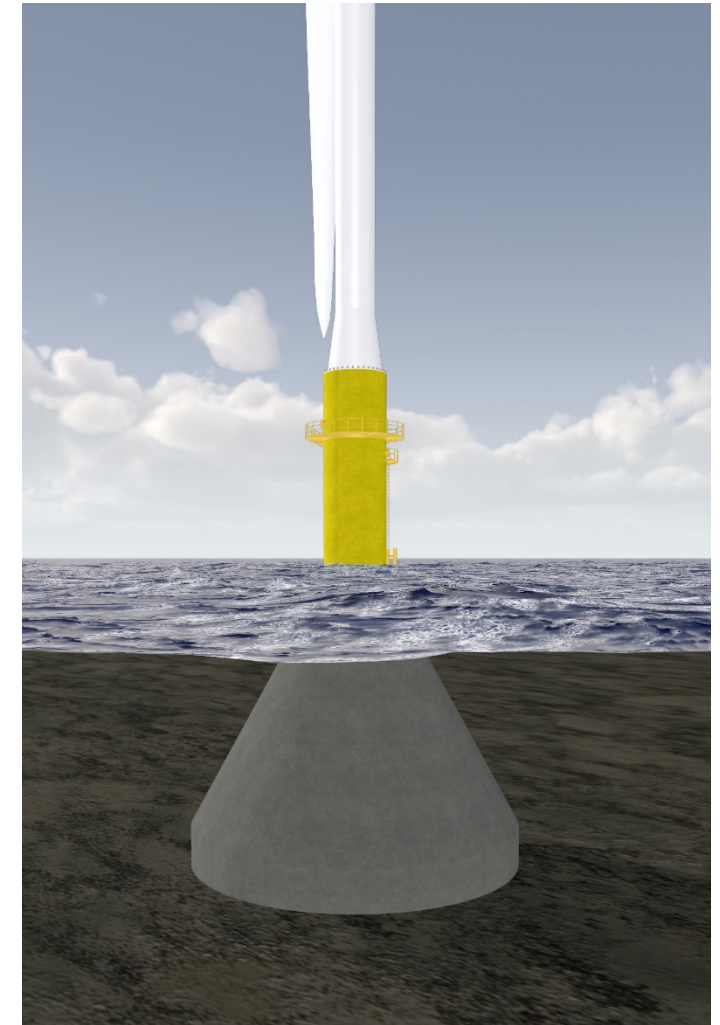

Weight of concrete support structure:
8000 t for 20- 50 m water depth
without ballast

The Concrete Gravity Base Foundation (GBF) – Long lived

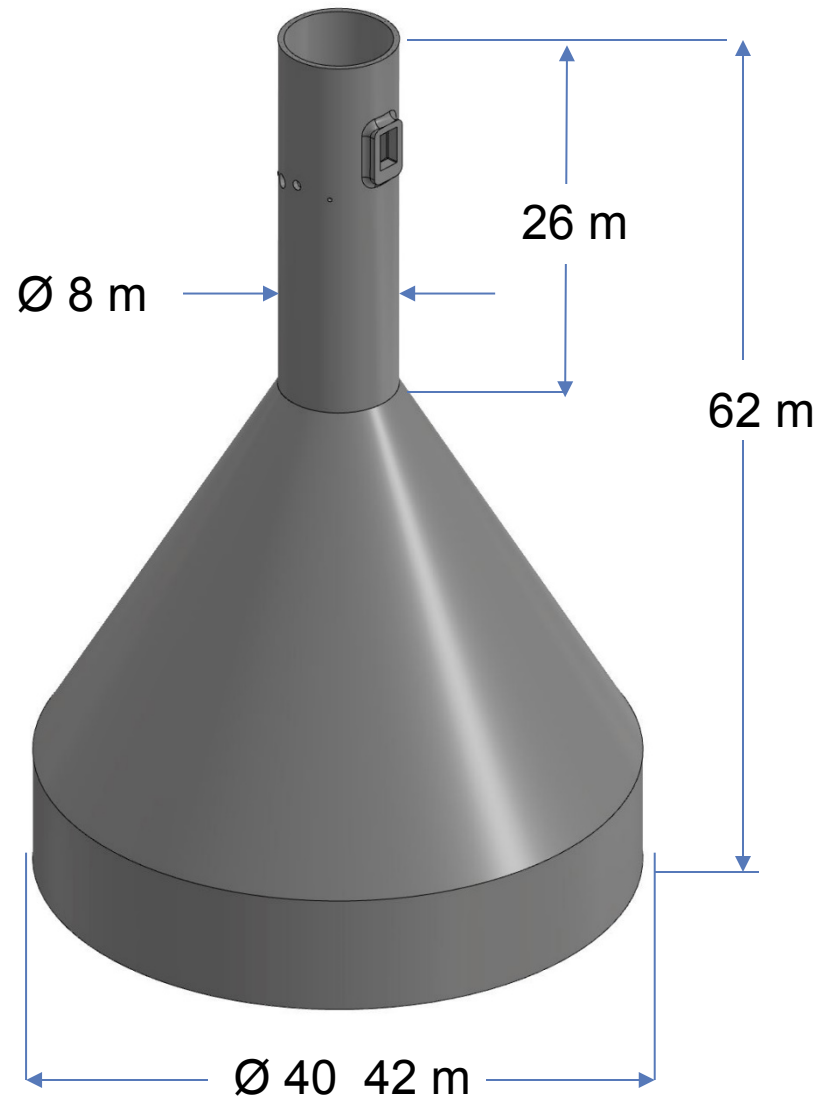

- GBFs are cheaper, when industrialized (serial production of foundation families), longer life time (up to 100 years, two turbine generations per foundation)
- This solution can be used in water depths from 35 to 50 meter
- The GBF has a positive impact on sea fauna (artificial reef, breeding space, habitat for crustaceans)
- Dismantling of the GBF with turbine is simple: deball-asting partially to bring it to floating again, then tow to key-side
- Seawind is looking with Clean-H B.V. and cement producers into CO₂-recycling for synthetic methane (Power-to-Gas)

Fast Build-Out - by Industrial Offshore Wind Assembly Line

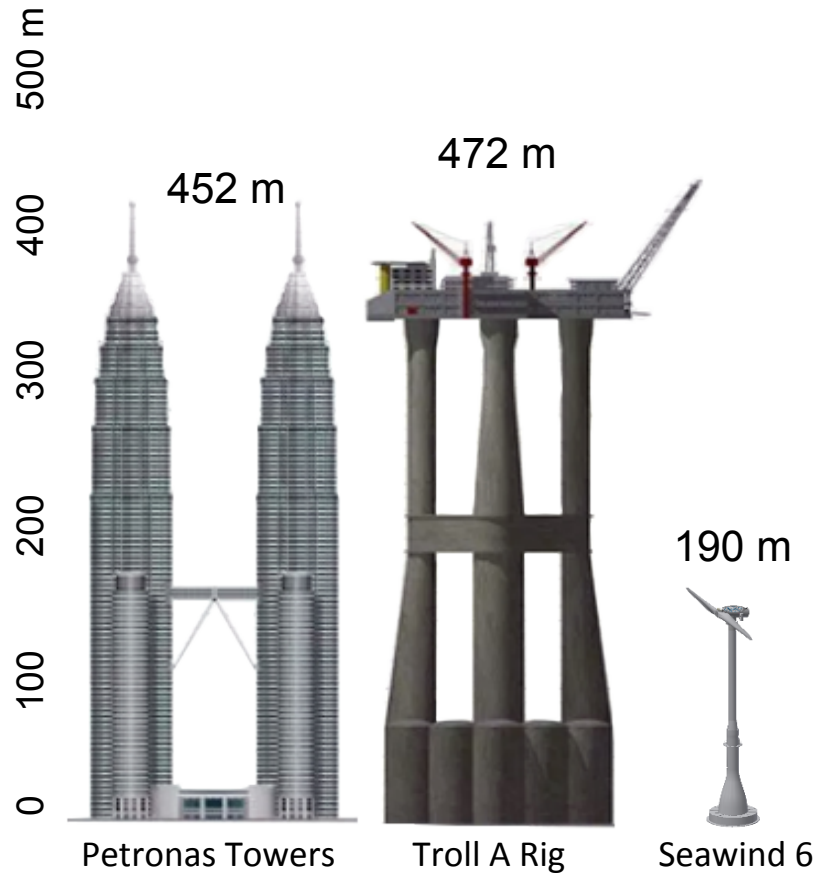

Petronas Towers and Troll A concrete oil platform (1.2 million t) designed by Olav Olsen and installed at sea as the Seawind units (20.000 t) will be installed: float over and sinking



Seawind introduces together with the **Blue Alliance** Strategic Partners a fast assembly line process in the offshore wind energy market, which reduces build-out time for large offshore wind farms to **less than one year** everywhere in the world.

No need to create expensive infrastructure in existing harbours!

Seawind Patent Overview

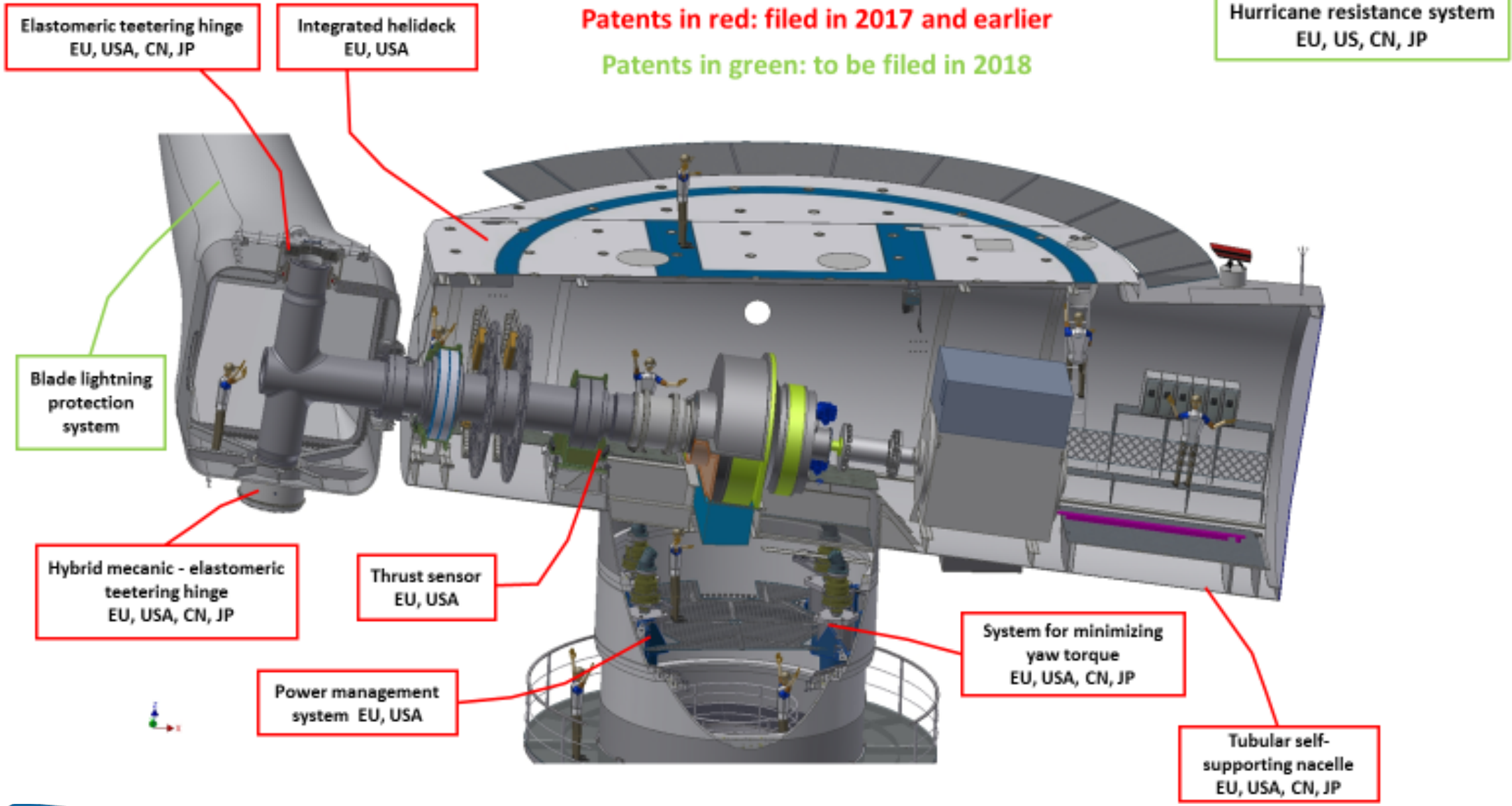

Unique installation method – Industry benchmark

The **complete system** is assembled onshore with land based cranes not offshore with expensive vessels

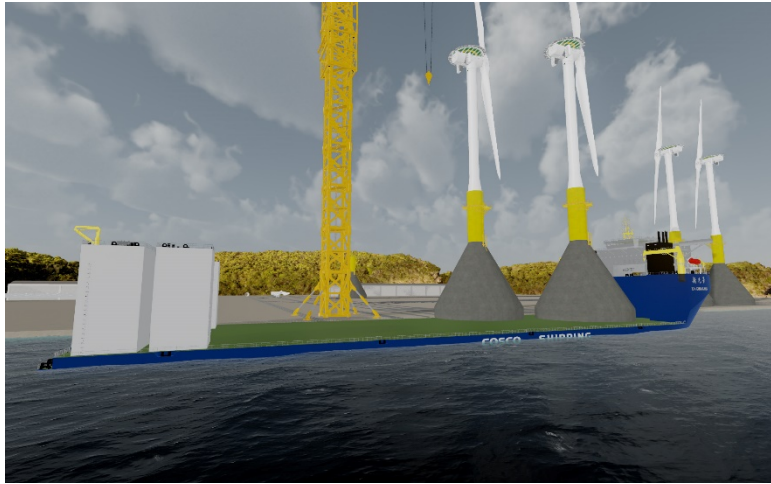

..... and transported, 4 or 6 at a time, to the wind farm location by semi-submersible vessels



The **semi-submersible ship unloads** the units, which are towed by tug boats for final positioning

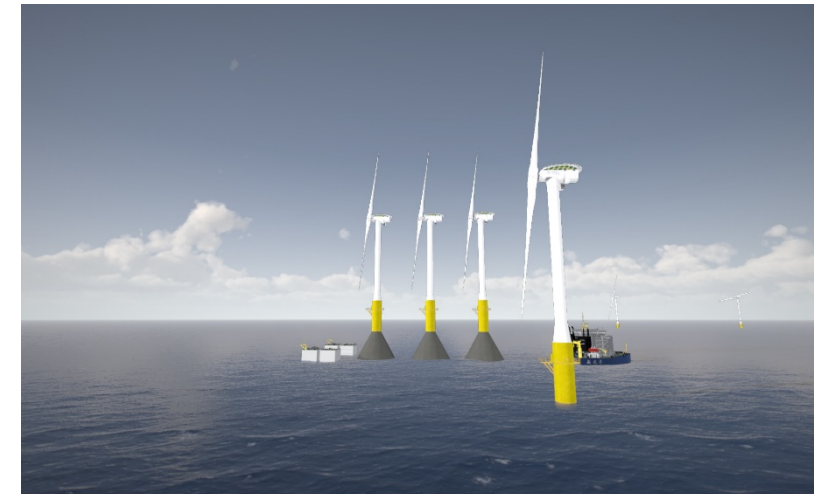

Pillar 3: Installation – By Sinking, No Lifting at Sea

- Seawind uses buoyant concrete foundations, which are built on a pier or in a dry dock and completed there with tower, nacelle and rotor
- The complete units are moved onto a submersible vessel, either mechanically or floated from the dock onto the vessel
- The vessels bring 4 – 6 units to the windfarm site where the units are launched into the water by sinking the entire vessel with the units
- Once the units are floating they are positioned by tug boats to the final position and lowered to the ground adding water ballast by pumping.
- After touch-down, additional sand and water ballast is added to secure stability in operation.

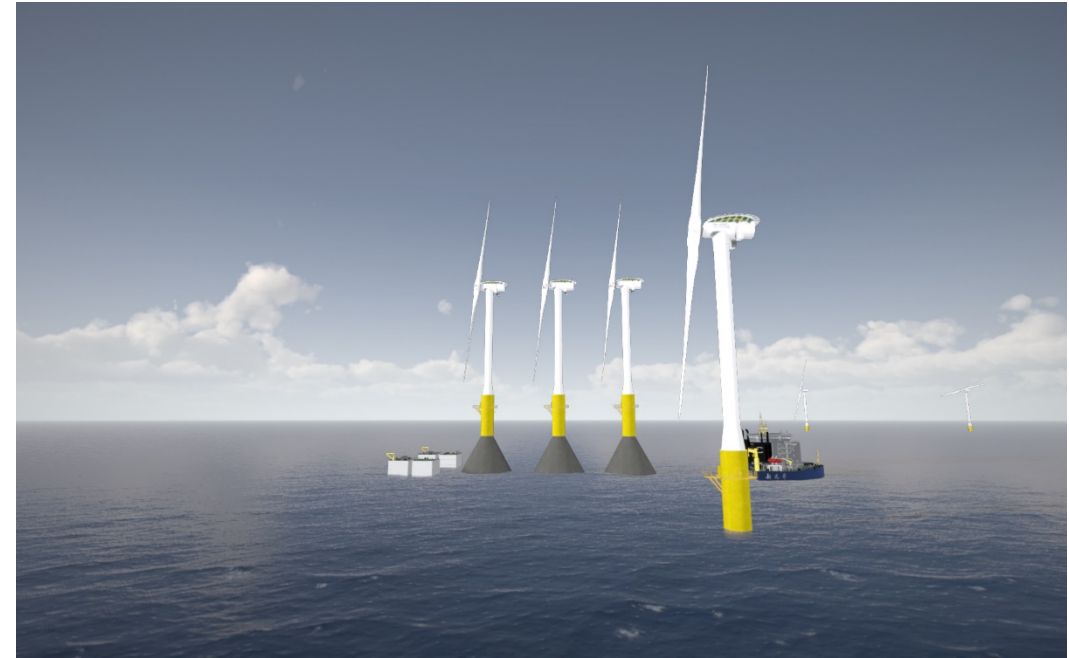

A COSCO semi-submersible vessel unloading 4 complete units at the site

Proven design - scaled up Innovative Offshore Energy System

System	Components	Origin	Advantages	TRL: Technology Readiness Level (1 = low; 9=high)
Turbine	2 Blades ⁽¹⁾	Nasa / United Technologies	Lower torque / Typhoon prone / Less Capex / Lower LCOE	TRL9
	Teetering Hinge ⁽²⁾	Nasa / Helicopter industry	Breaks the gyroscopic system / Less stress on system / 90% less Yaw Torque / Lower LCOE	TRL 9 (redesign)
	Yaw control ⁽³⁾	Glidden Doman	Uncomplicated control mechanism / No blade pitch control	TRL 9
	Controller software ⁽⁴⁾	Seawind	Optimised system management	TRL 8
	Stiff Tubular Steel nacelle ⁽⁵⁾	Seawind	Vibration free drive train / Safe access through Helideck	TRL 8
	Other equipment ⁽⁶⁾	Standard equipment	Standard components with longer lifetime due to lower stress	TRL 9
Foundation	Self sinking concrete structure ⁽⁷⁾	Norway / Olav Olsen	Low cost when industrialized / Local construction / Buoyant system / Longer lifetime / Lower LCOE	TRL 9
Installation	Complete assembly at harbour ⁽⁸⁾	Seawind	Low cost & faster roll out/ No expensive offshore installation vessels / Less weather dependent	TRL 7

¹ Nasa, sponsored by DOE has built multiple 2 bladed wind turbines that have been successfully operated for many years

² Originating from the helicopter industry NASA adopted the technology which was further refined by Seawind energy & helicopter engineers (<https://ntrs.nasa.gov/archive/nasa/casi.ntrs.nasa.gov/19810019068.pdf>)

³ Glidden Doman introduced the Yaw Control successfully at the Gamma 60 project in Italy which was used as test facility for 6 years

⁴ Seawind has developed the Controller software in house based on the new design, verified Seawind simulations (prof. Bottasso TU Munich) and the Gamma 60 results

⁵ Seawind design for high stiffness (patent pending). Helicopter deck itself is proven technology

⁶ All other equipment is 'off the shelf' equipment also used by other offshore wind solution providers

⁷ Numerous GBS foundations have been installed in the O&G industry in 15 - 350 m deep waters

⁸ Normal onshore construction industry methods

BLUE ALLIANCE - Partner Strategy

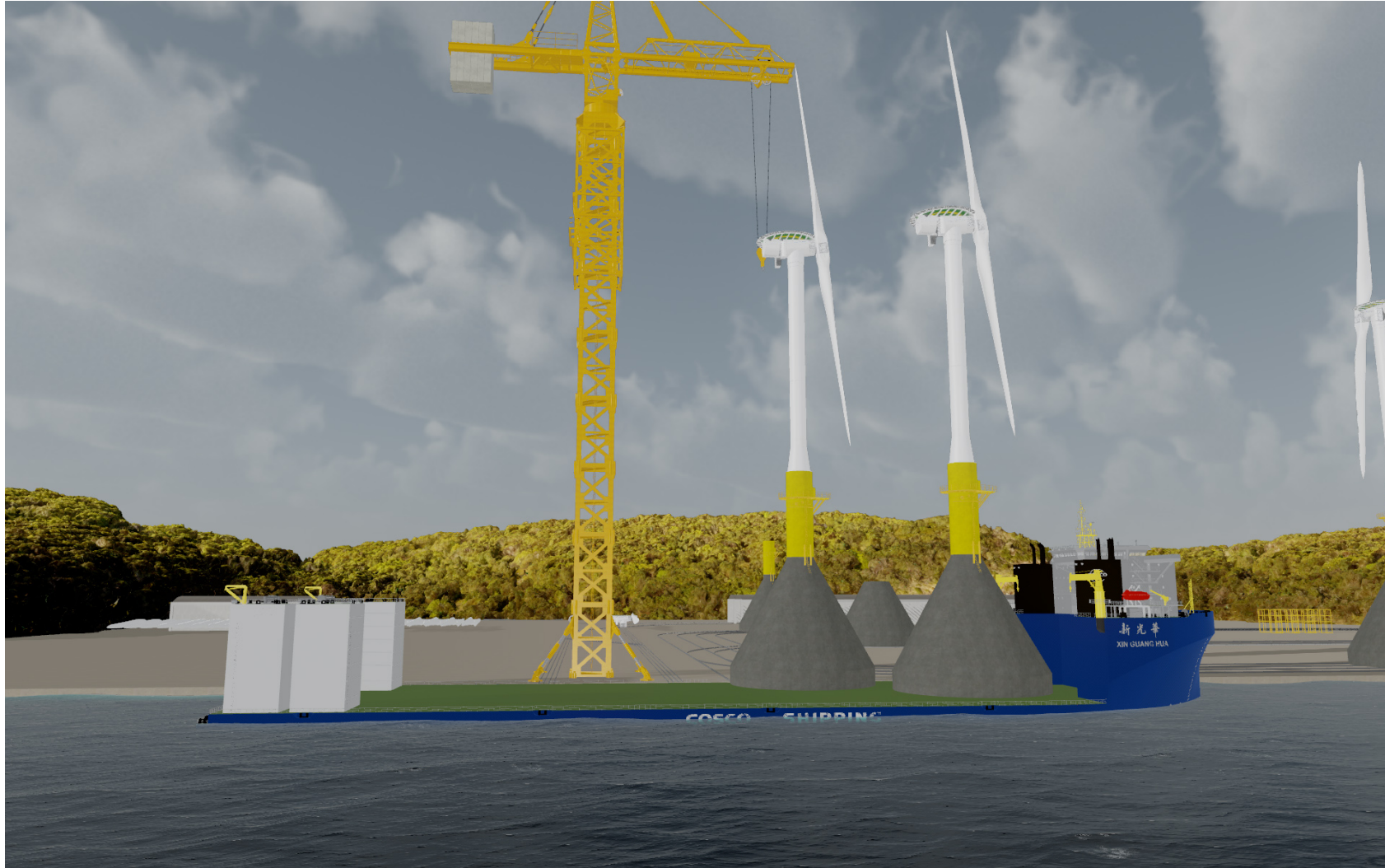

A COSCO semi-submersible vessel being loaded at the production plant

Blue Alliance – Eco system of Seawind Partners

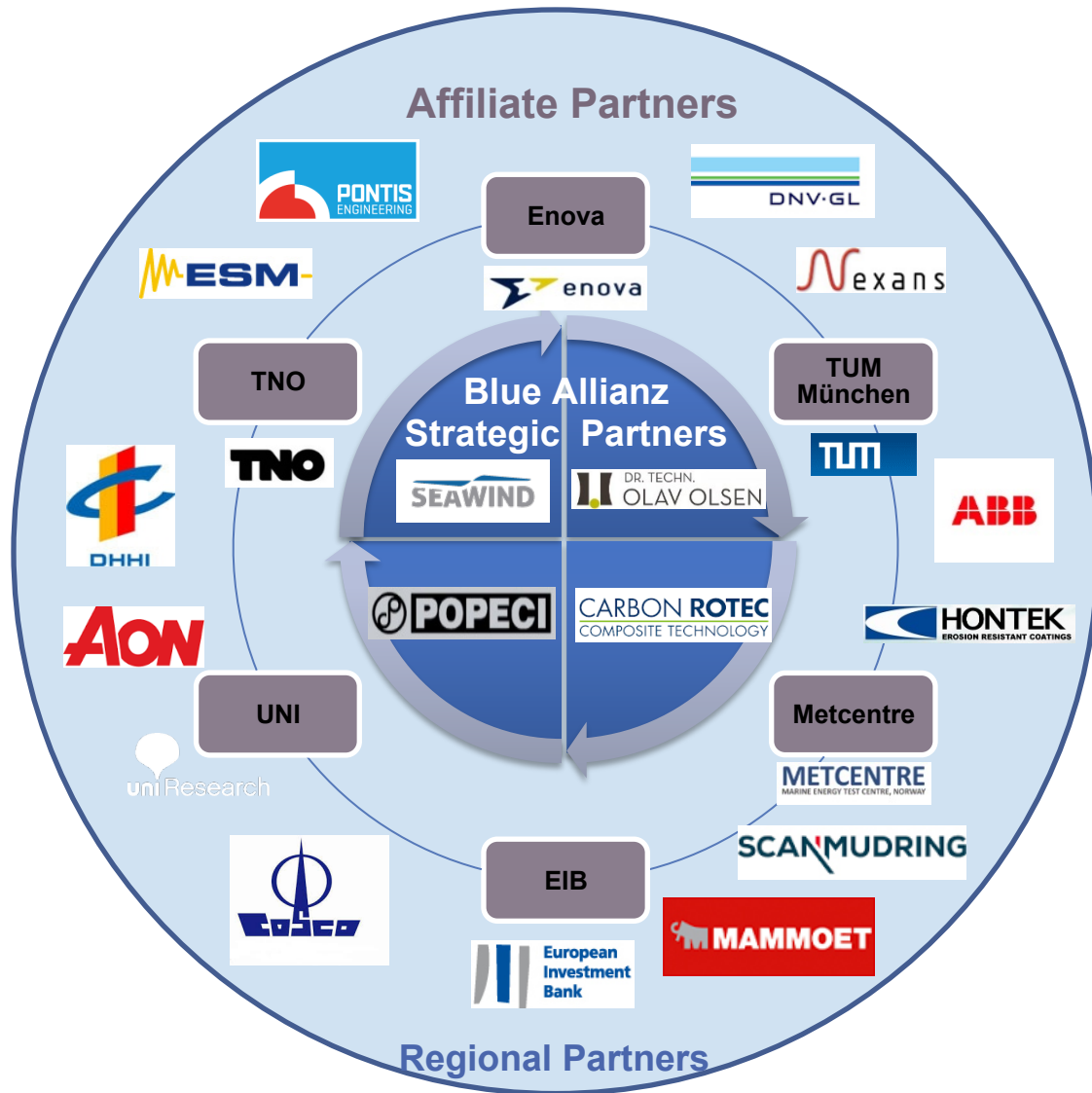

Strategic Partners

Global partners with clear motivation to enable Seawind's technology contributing with financial and other resources to gain certain upfront rights. Blue Alliance will provide the guarantee to customers

Affiliate Partners

Industrialization partners with distinct resources &/or relevant supply chain capabilities for Seawind's development

Public Enablers

Prepared to take a certain risk to bring innovation to the market to meet society's needs

Regional Partners

Local or regional stakeholders with strong connections and local know-how including relevant access to potential off-shore sites, local grid, etc. high local content (Regional Partners not shown in the graph)

Click on logo to get to partner web-site (in Slide Show mode)

Norway Hub Locations - Seawind Demonstrator site

Demonstrator construction and future Industrialization



BLUE ALLIANCE – Global roll-out ambition

Global markets for wind energy - Blue Ocean [B] and Red Ocean [R]

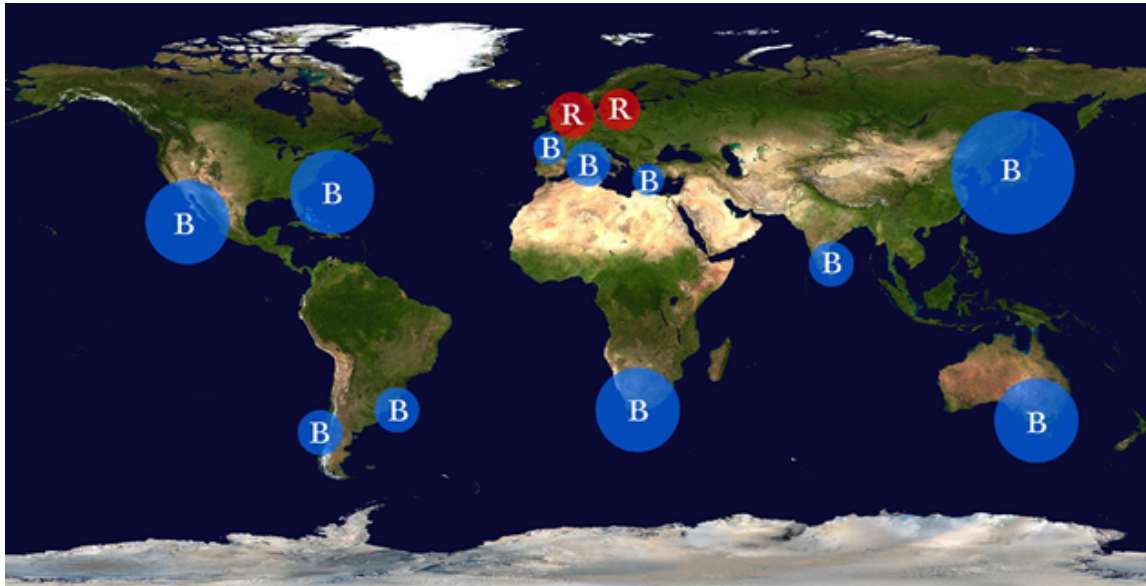

- R** Red Ocean market:
 - contested market space, covers 11% of global market potential*
 - major offshore wind companies are expanding their EU presence in offshore sites with favourable attributes
- B** Blue Ocean market:
 - uncontested market space and competition has not developed the required technology nor the supply chain to start operations in the near future

Out of the 7522 MW to be built by 2025 by Blue Alliance 50% capacity in hurricane/typhoon areas

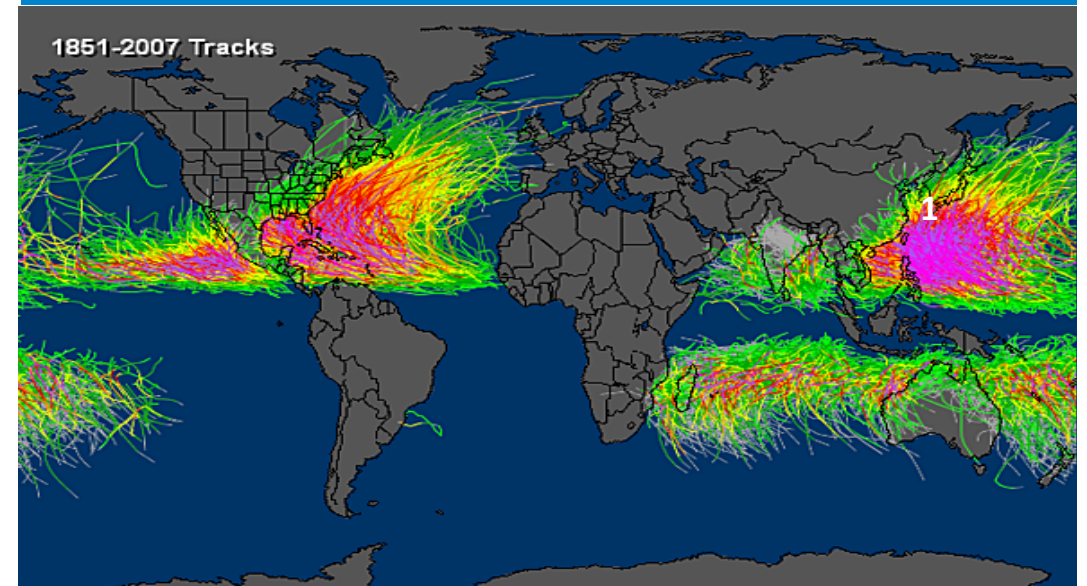

- Seawind has 4% market share of the global Offshore capacity added in the period 2019-2025
- 60 Offshore Wind Farms are built
- 50% Seawind capacity in hurricane/typhoon prone areas
- 7 Million households in Europe or over twice that number in developing countries have sustainable power
- CO₂ emissions are reduced by more than 9 Million t/year

Initial Commercial Projects - Cyclone Areas

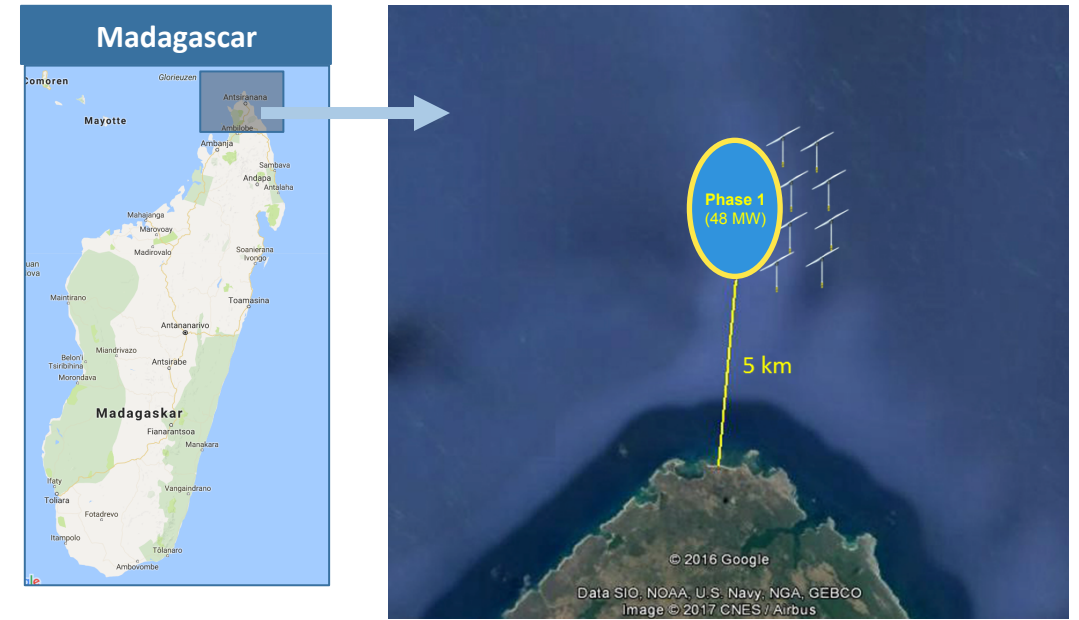
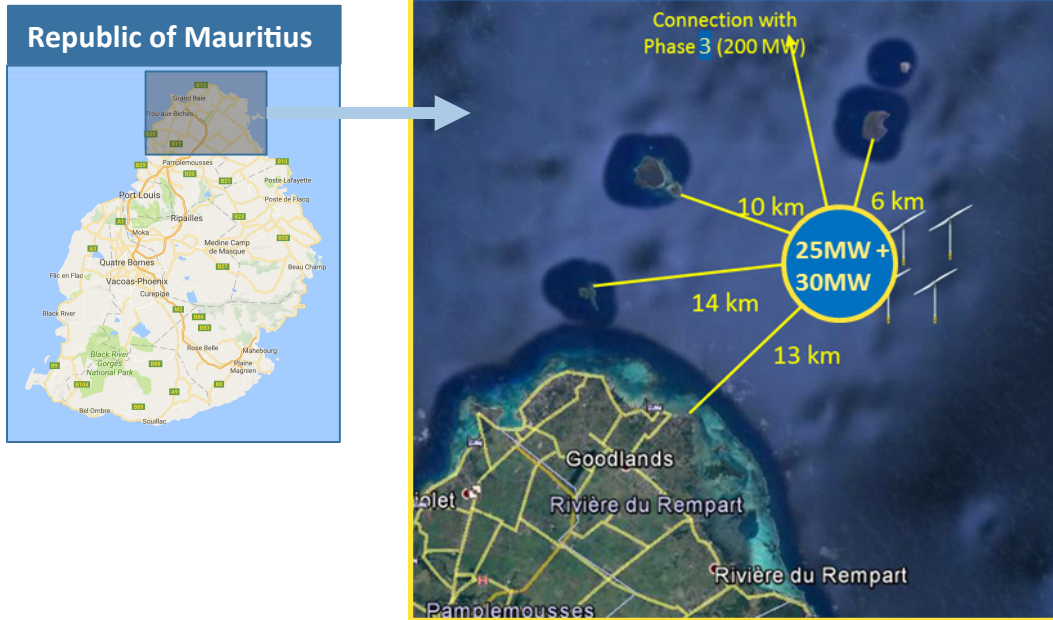

Planning

- Project development in close cooperation with leading local construction company (2017-2018)
- Joint effort in setting up the local wind farm ownership and operational structure (2018)
- Three phase approach:
 - Phase 1: ~ 25 MW, 4 Seawind 6, bottom fixed
 - Phase 2: ~ 30 MW, 3 Seawind 10, bottom fixed
 - Phase 3: ~ 200 MW, ~ 20 Seawind 10, floating
- Obtain concession for sea area and define grid connection point and kWh tariff (2019)
- Contracts for financial closing of Phase 1 (Q4 2019)
- Start build out in Q1 2020
- Phase 1 operational Q4 2020

Planning

- Project development in close cooperation with leading local construction company (2017-2018)
- Joint effort in setting up the local wind farm ownership and operational structure (2017)
- Obtain concession for sea area and define grid connection point and kWh tariff (2018)
- Contracts for financial closing (2019)
- Start build out in Q4 2019
- Operational Q3 2020

Seawind – Pipeline developing fast

Seawind 6.2MW		2019	2020	2021	2022	2023	2024	2025	Total	Construction	
Seawind 10MW		MW							MW	in	
1	Mauritius	-	25	-	30	-	200	-	255	Norway	
2	Madagascar	-	-	50	-	100	-	200	350		China
3	Papua New Guinea	-	-	25	-	-	100	-	125		China
4	China, starting with Fujian	-	-	200	-	300	400	500	1400		China
5	India, Tamil Nadu	-	-	50	200	300	-	300	850		China
6	Sri Lanka	-	-	-	50	200	-	-	250		China
7	Greece	-	-	100	-	200	-	400	700	Norway	
8	Portugal	-	-	-	-	-	300	-	300	Norway	
9	Estonia	-	-	-	-	-	-	100	100	Norway	
10	Ireland	-	-	-	-	200	-	-	200	Norway	
11	The Netherlands	-	-	-	-	-	350	500	850	Norway	
12	Germany	-	-	-	-	-	500	500	1000	Norway	
13	UK	-	-	-	-	100	-	300	400	Norway	
14	Caribbean	-	-	-	25	-	300	-	325	Norway	
15	Norway	Demonstrator	-	-	-	200	-	-	200	Norway	
16	Philippines	-	-	-	200	-	-	-	200		China
17	USA	-	-	-	-	-	300	750	1050	Norway	China
18	Spain	-	-	-	-	-	150	-	150	Norway	
19	Vietnam	-	-	-	100	-	150	150	400		China
20	Australia	-	-	-	50	-	200	200	450		China
Total MW		0	25	425	655	1600	2950	3900	9555	4.680	4.875
Cumulative MW		0	25	450	1105	2705	5655	9555			
Number of Seawind Turbines		0	4	68	88	160	295	390			

Hurricane areas bolded in red
Seawind 10MW bolded in blue

Seawind – Company Structure

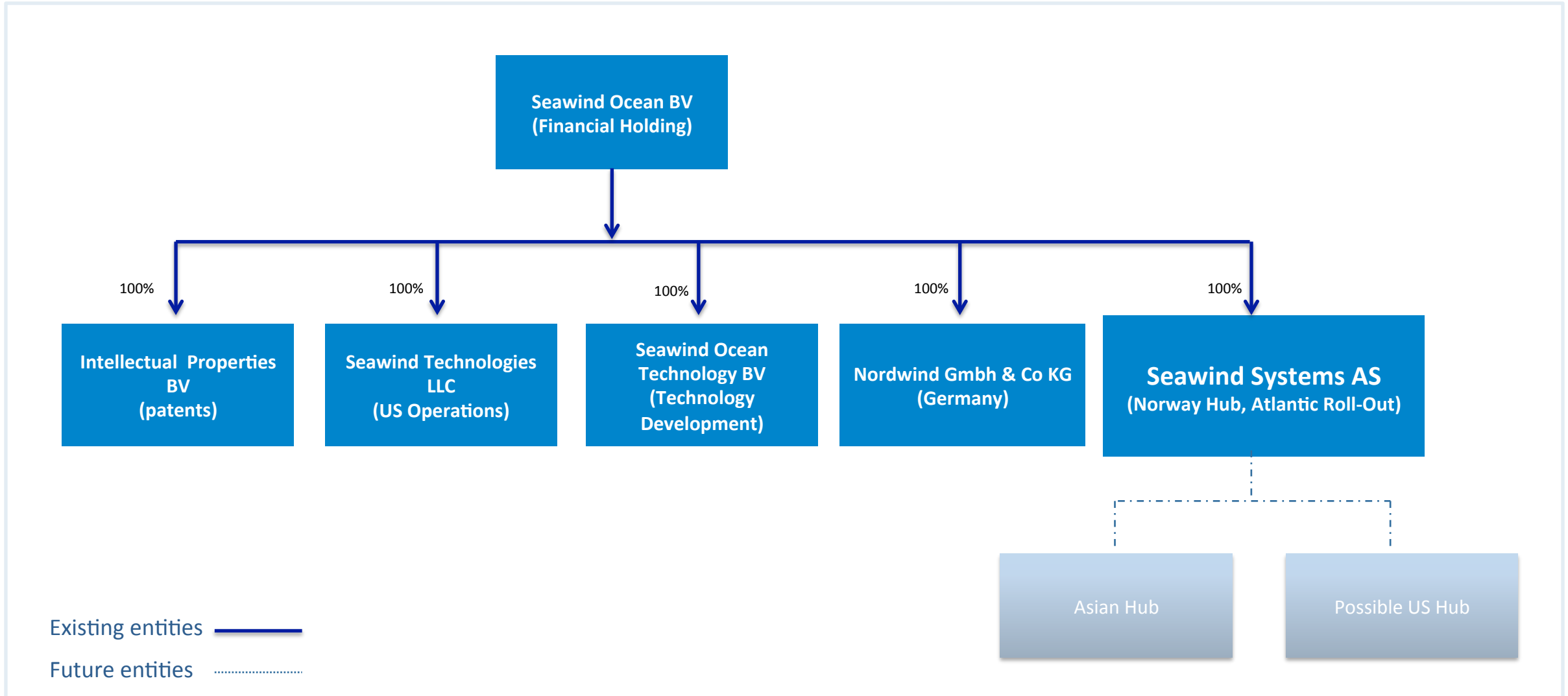

Seawind - At a glance

Seawind Ocean Technology is a leading **Turnkey Offshore Wind Farm Supplier**. The unique 2-bladed Seawind turbine technology originates from NASA that built the first 4MW system onshore in 1982. The wind turbine design has been running onshore successfully in the US and Europe and is now to be installed offshore along the coast of Norway.

Key benefits:

- **Lower Capex and Opex** than any other offshore wind solution
- **Lowest life cycle cost** for offshore wind farm systems, below € 0,08 ct/kWh installed offshore
- **Hurricane (category 5) resistance**
- **Easy installation** everywhere avoiding costly specialized equipment, people, infrastructure, heavy crane vessels conventional turbines require
- **Complete Offshore Wind Energy System** (wind turbine, support structure and low cost installation)
- **Robust design with easy, low-cost maintenance** that can be done by local contractor
- **Wind Turbine Lifetime of 30 years** compared to 20 years for traditional three-bladed wind turbines

The company has been reviewed by peers.

- The European Commission awarded the technology a **Seal of Excellence**
- Certification of the technology through **DNV-GL**
- Seawind's combined engineering experience with two-bladed wind turbines, which well exceeds 60 years, combined with significant on- and offshore wind project management and relevant industrial partnerships. The Seawind management installed the first ever floating wind turbine.





THANK YOU